



Institut für
Integrierte Produktion Hannover

CWR machine

CAD design



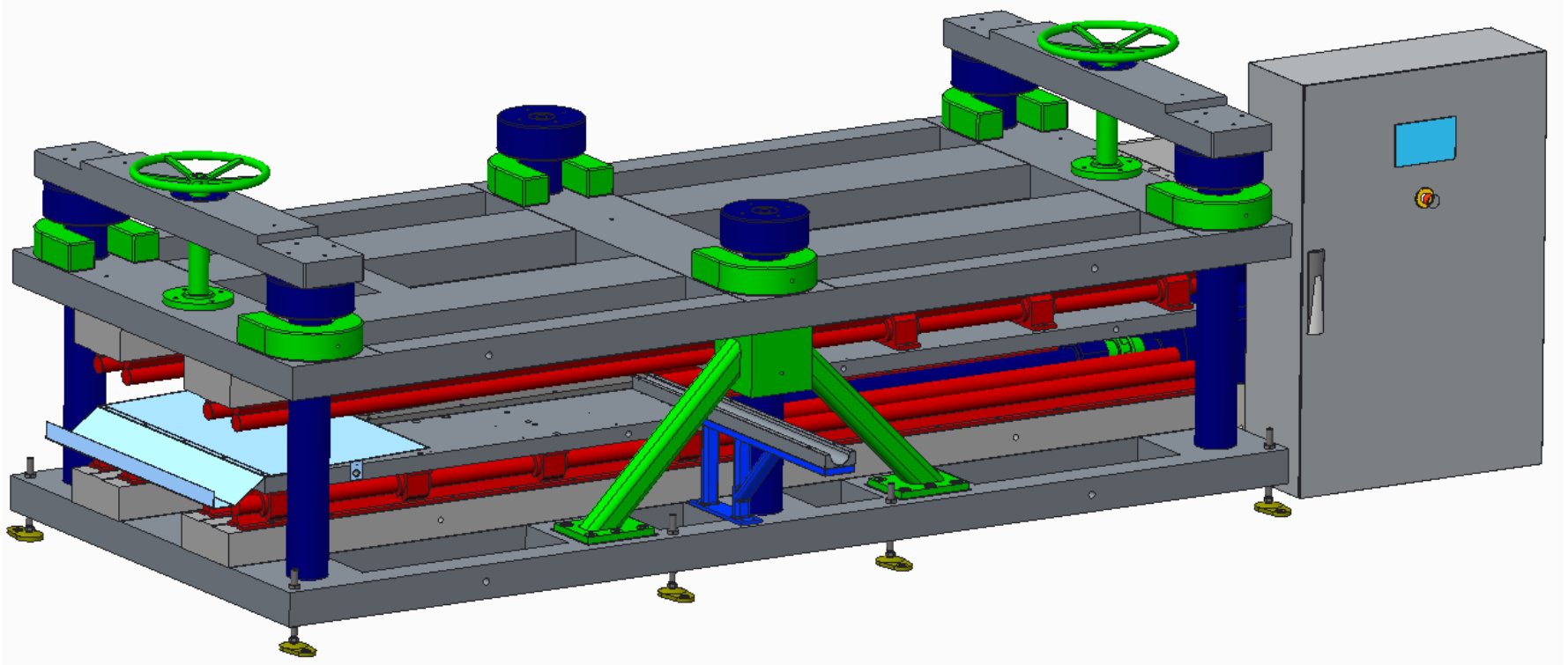



CWR machine – complete

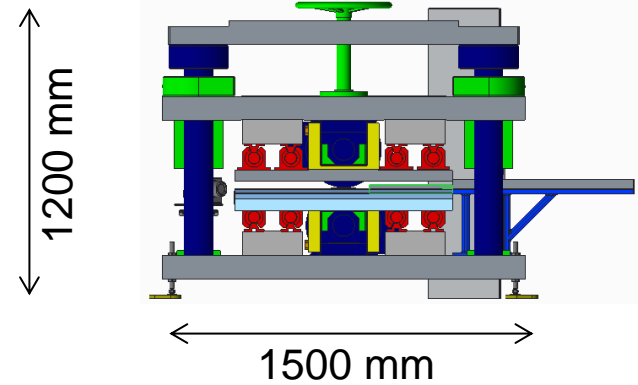
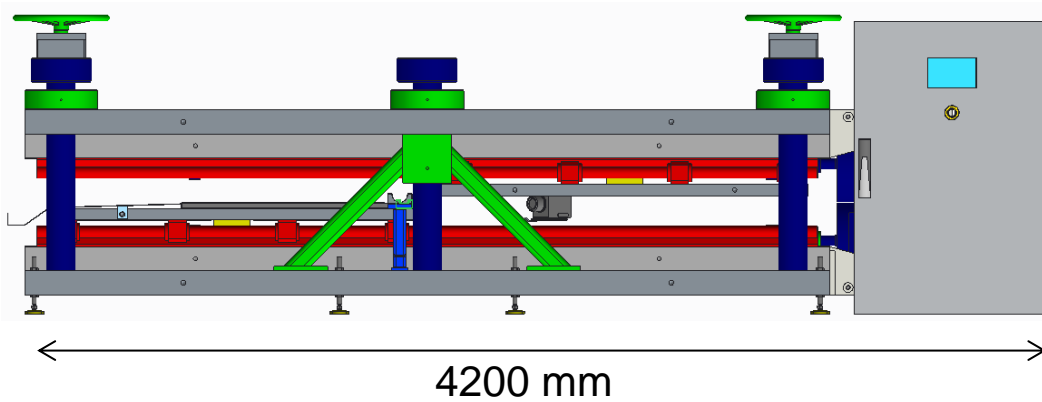
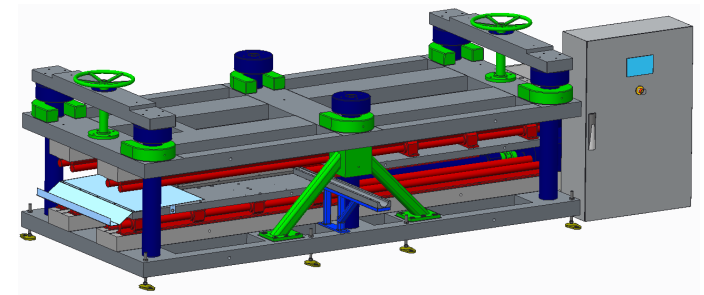
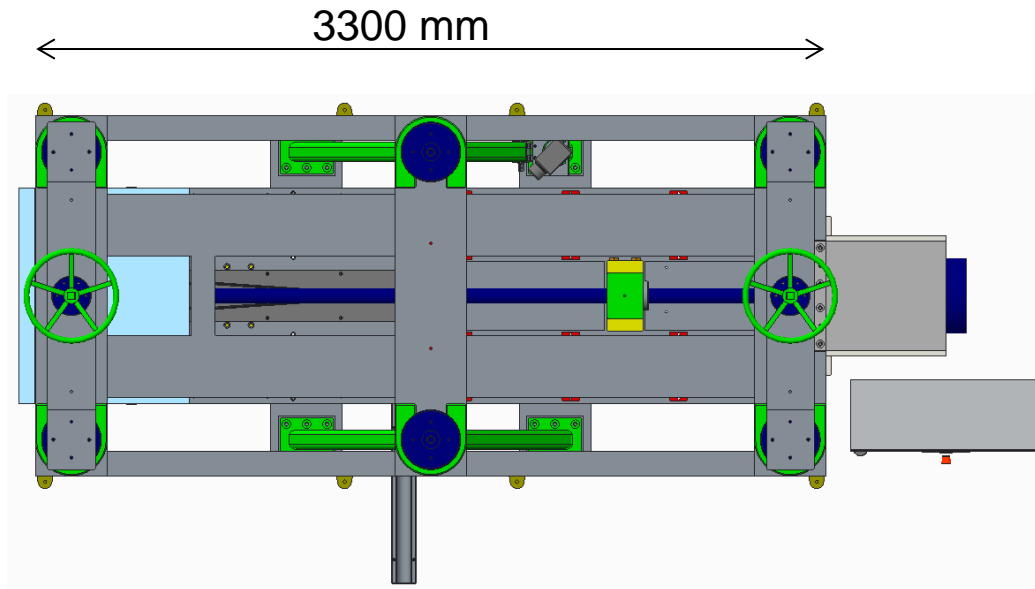

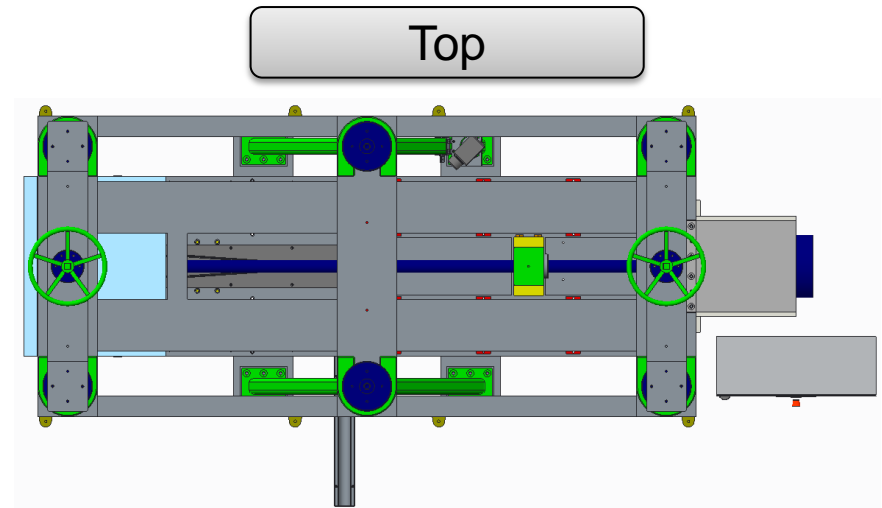
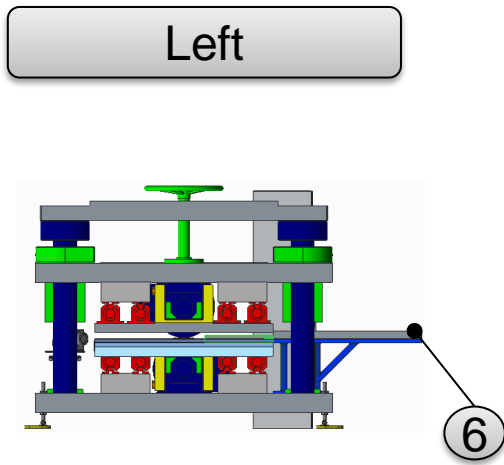
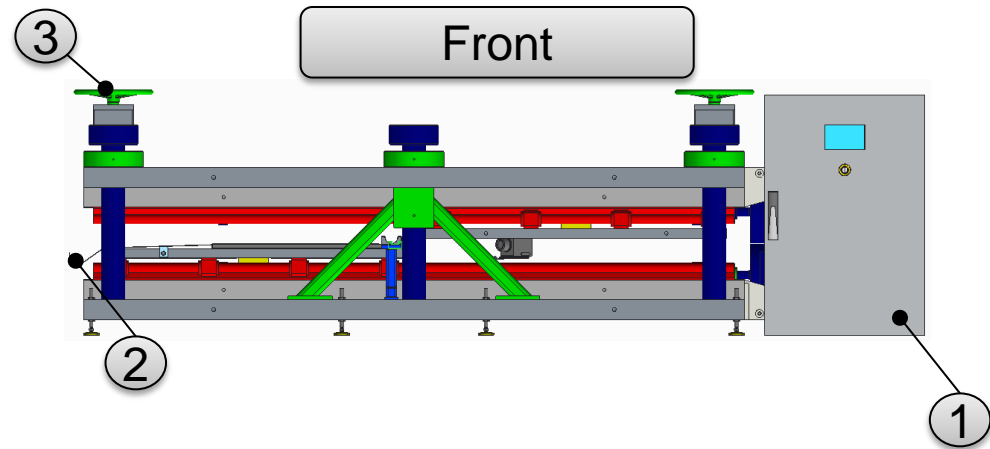
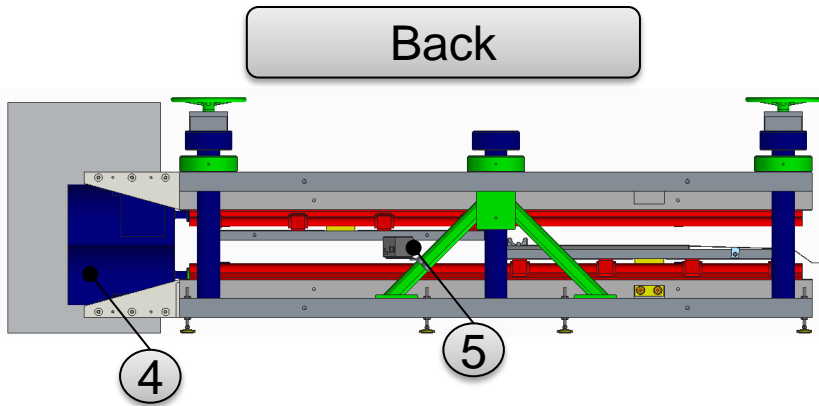

- 1: Control cabinet
- 2: billet removal system
- 3: trapezoidal thread spindle with hand wheel for vertical movement of the upper tool

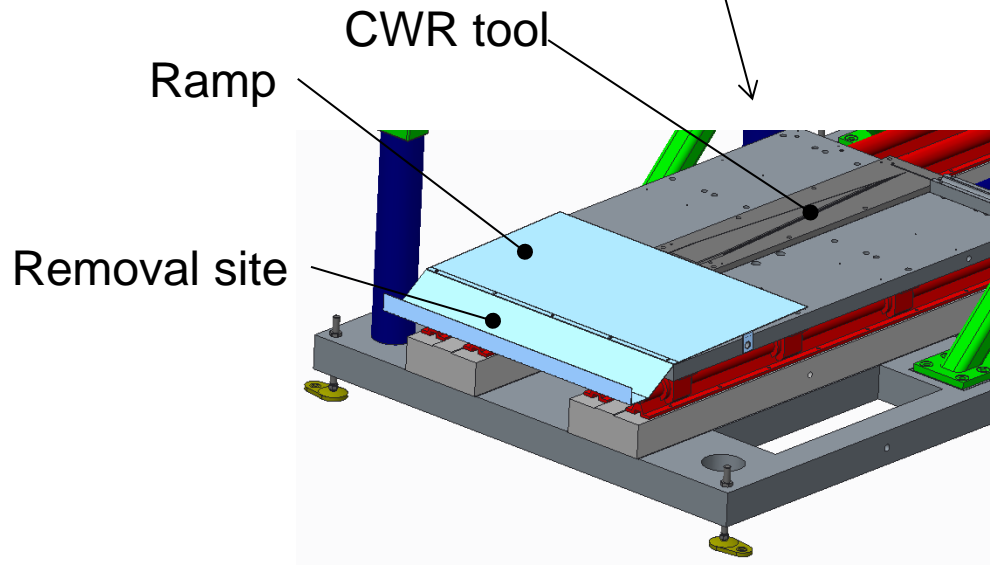
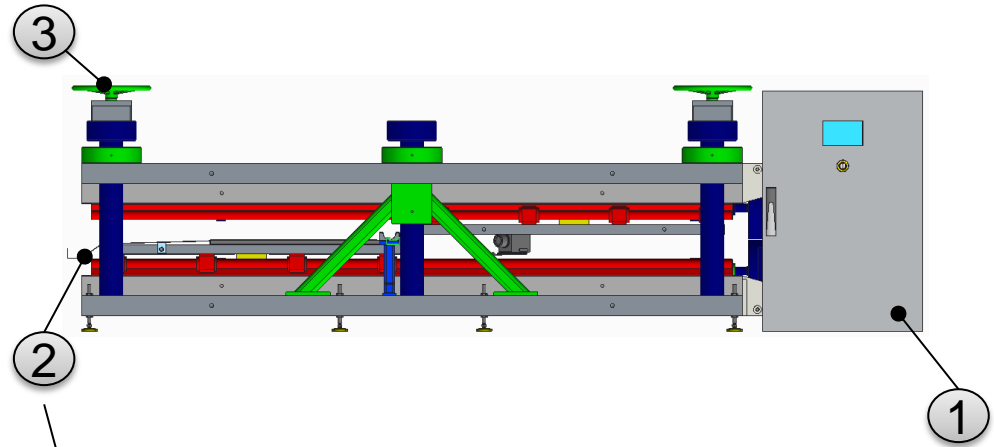

After the rolling process, the billet rolls down the ramp and into the removal site.

Picking up the rolled part manually.

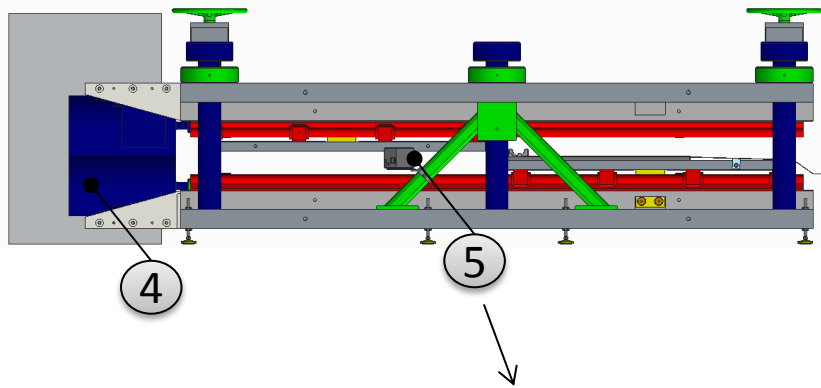

4: electric motor

5: Thermographic camera

Adapter plate for variable positioning

Thermographic camera Vario Cam 2

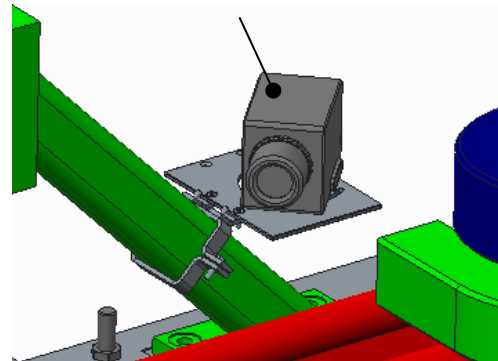
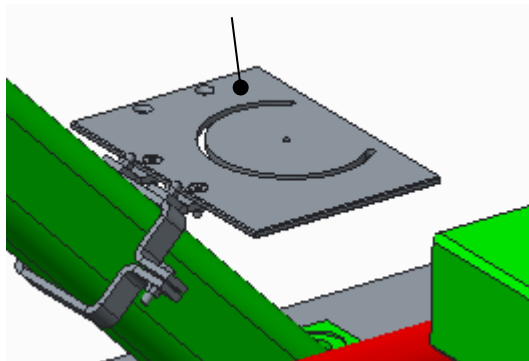

The adapter plate can be easily mounted onto the cross brace and the height set up freely. The angle of the camera and therefore the view to the billet position can simply be changed.

CWR machine – detailed view

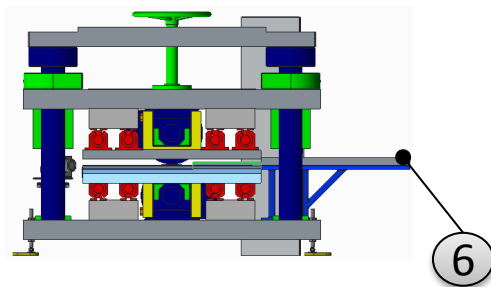
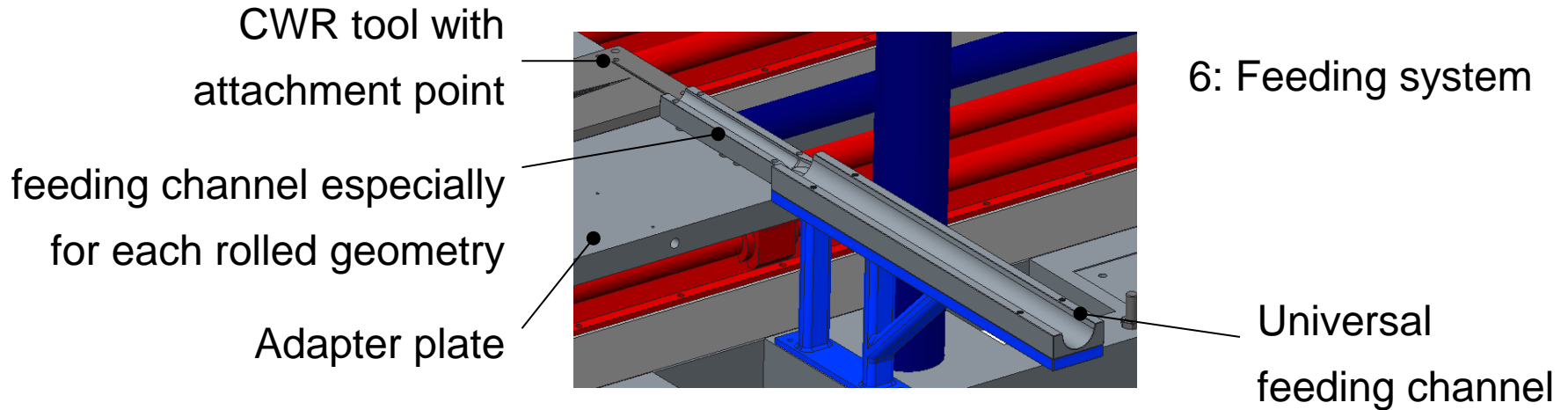

The hot billet is placed on the feeding channel and then can be pushed over the feeding channel on the adapter plate onto the CWR tool. The attachment point and the groove ensure a correct initial position of the billet.



Contact person

Dipl.-Ing. Thoms Blohm

IPH - Institut für Integrierte Produktion Hannover gGmbH
Hollerithallee 6
30419 Hannover



+49 (0)511 27976-335



+49 (0)511 27976-888



blohm@iph-hannover.de



www.iph-hannover.de